

Installation plan

Washer-dryer stack



PWT 6089 EL (Electrically Heated)

en - US

U.S.A.

Miele, Inc.

National Headquarters 9

Independence Way
Princeton, NJ 08540

Phone: 800-991-9380
609-419-9898

Fax: 609-419-4241

www.mieleusa.com

Technical Service & Support

Nationwide

Phone: 800-991-9380

Fax: 800-220-1348

proservice@mieleusa.com

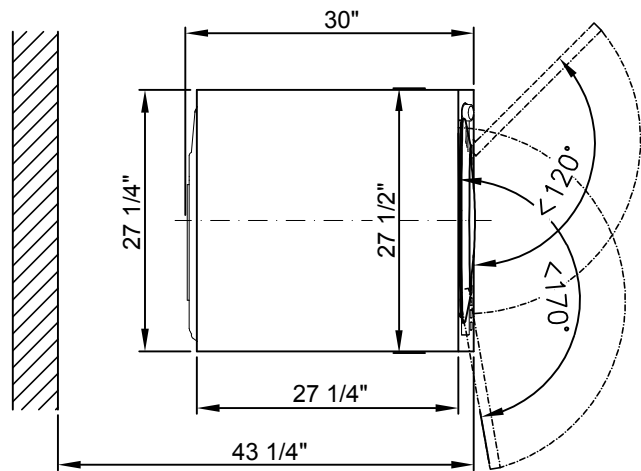
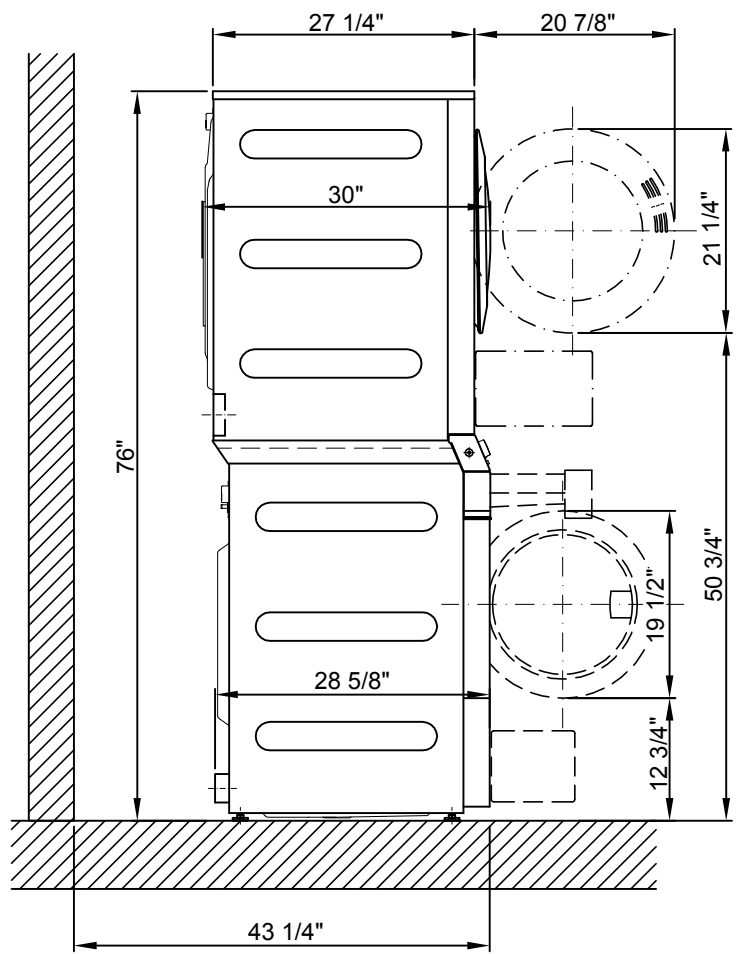
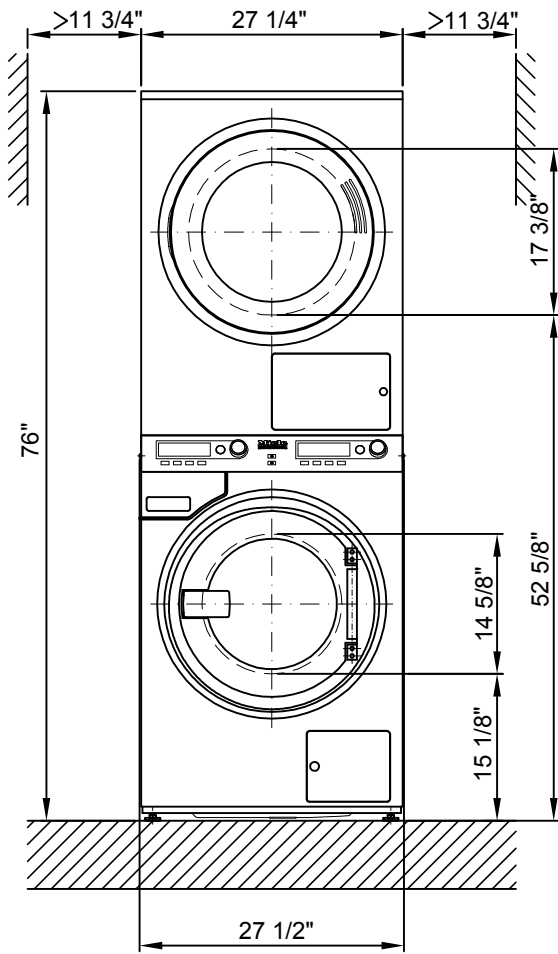

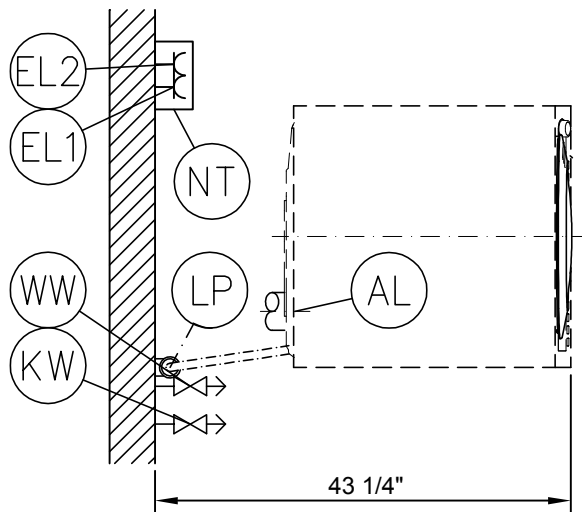
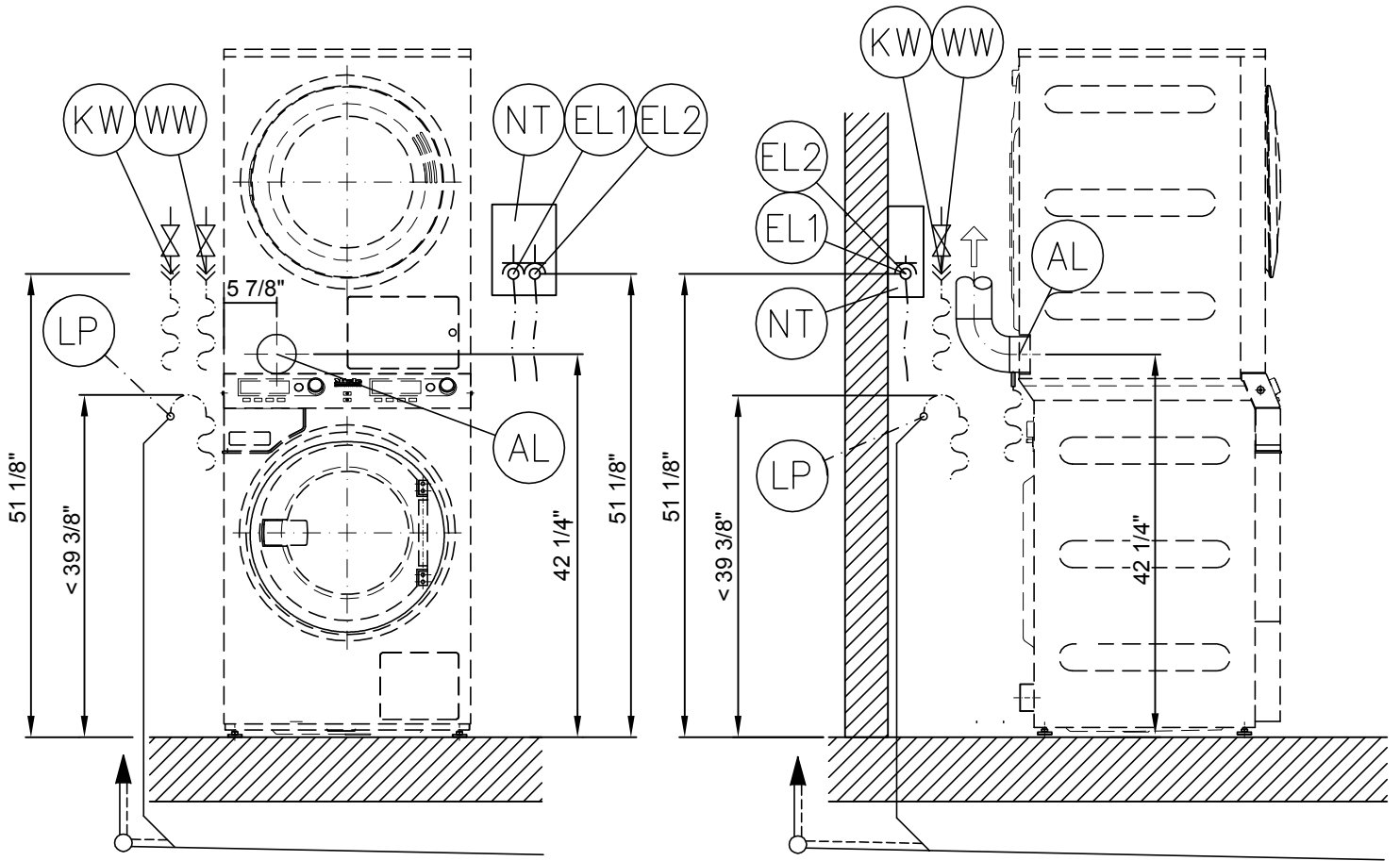

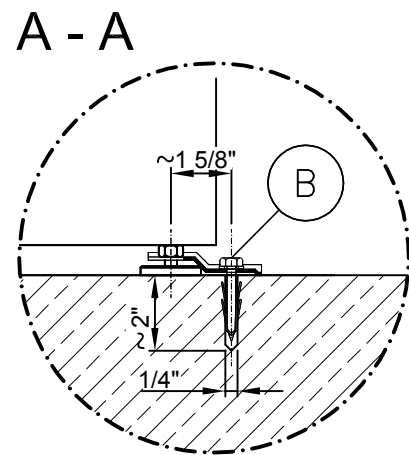
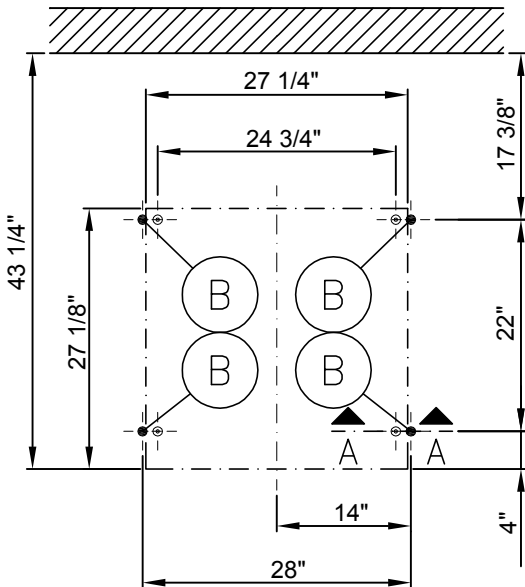
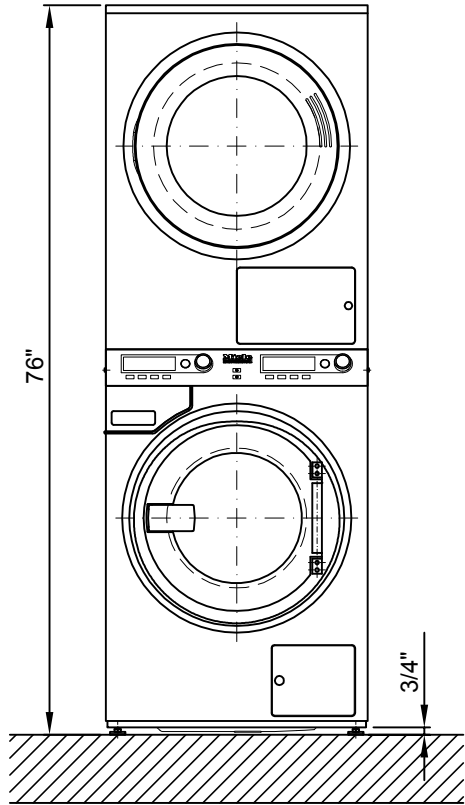

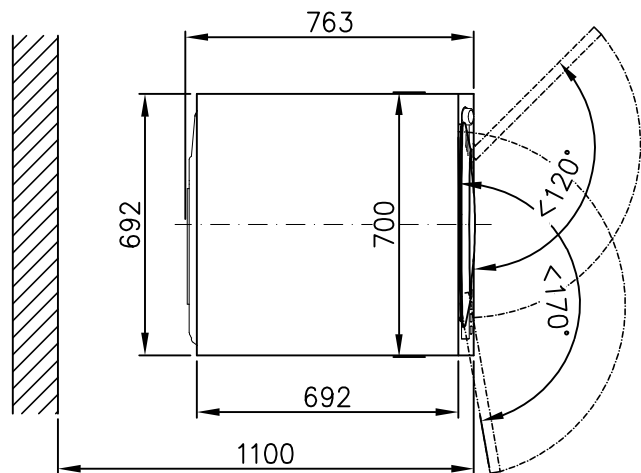
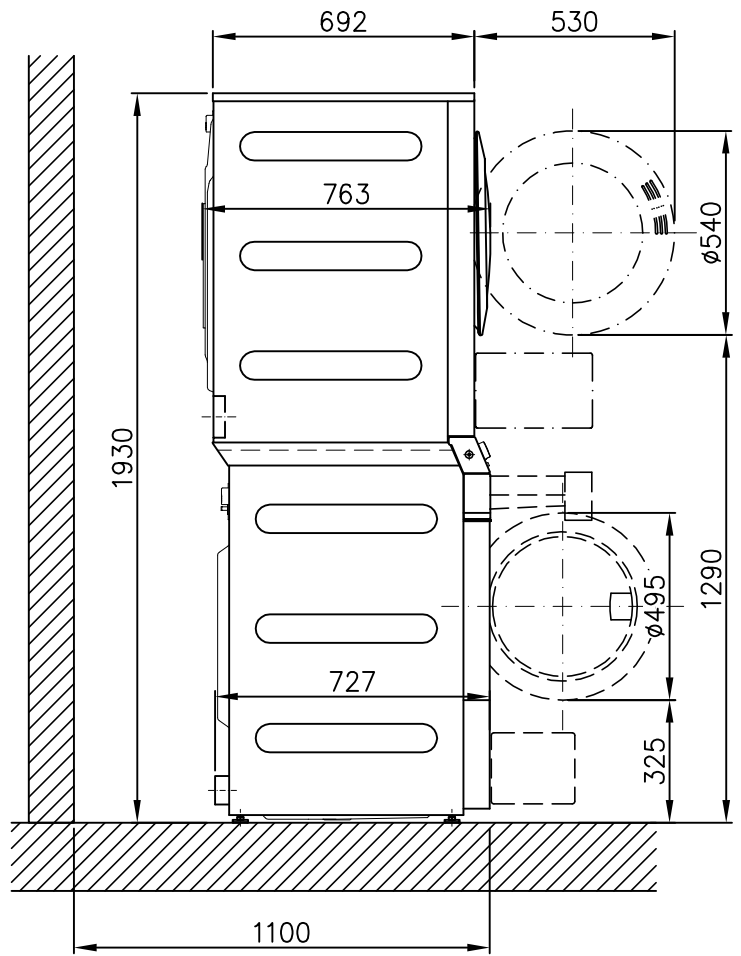
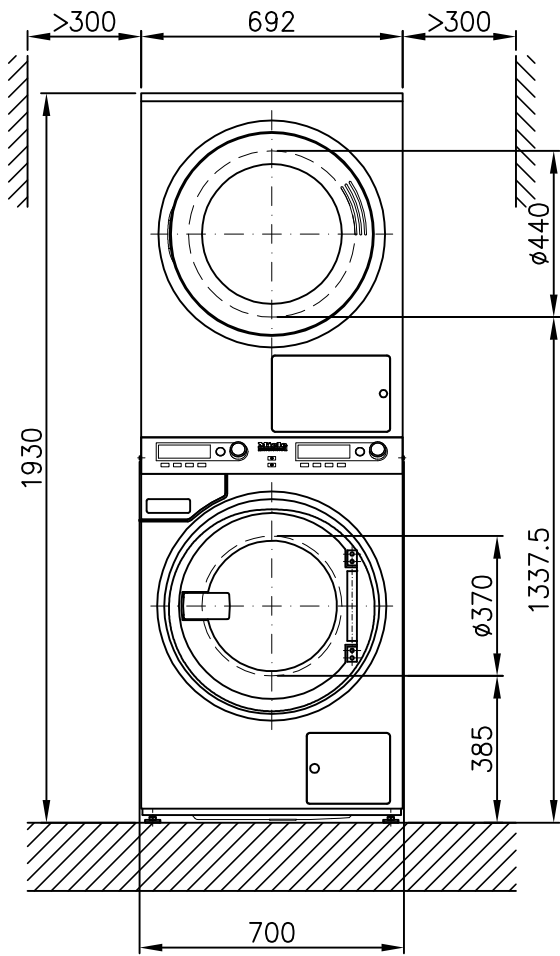

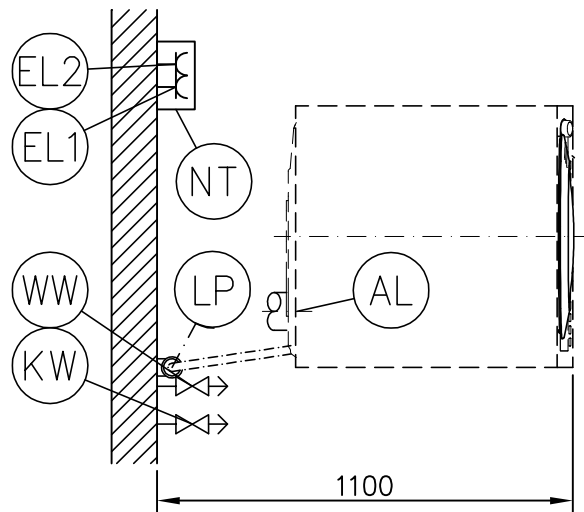
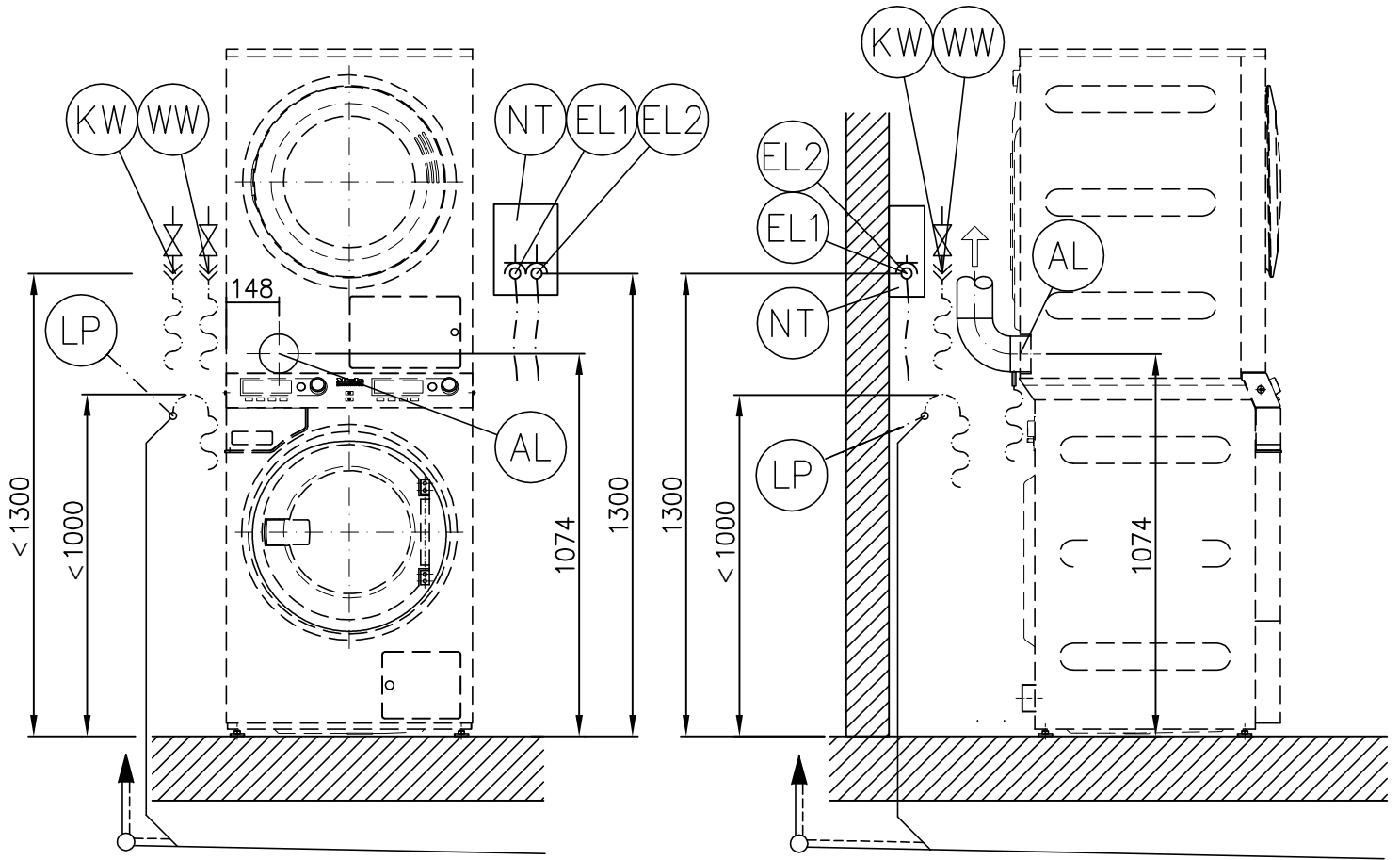

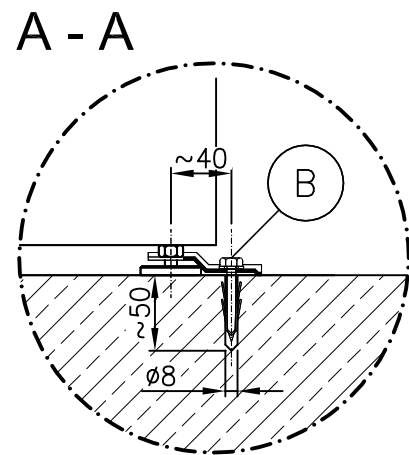
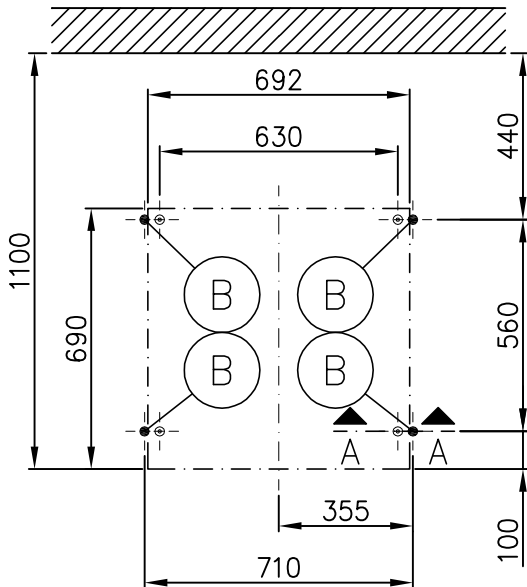
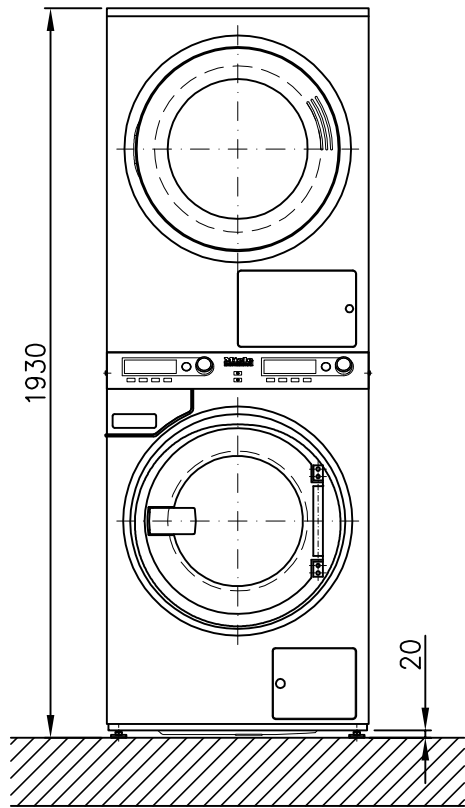

Technical datasheet



Washer/Dryer stack:
Heating:

PWT 6089 LP (Drain pump)
Electric (EL)

Legend:



Abbreviations in bold type:
Connection required



Abbreviations in circle with dashes:
Connection optional or required depending on model version

en - US

Options/accessoires:

	Dispensing pump	External dispensing pumps (2 or 4 head pump): Voltage (external power supply required) Fusing Supplied with supply cable and plug Pump installation may only be performed by Miele Service.		120V 15A NEMA 5-15
--	-----------------	---	--	--------------------------

Machine connections:

EL	Electrical connection	<p>Standard voltage (2 AC 208V/220-240V 60Hz) NOTE: Electrical connection depending on version ordered.</p> <p>Washer (EL1) – 2 AC 208V/220-240V 60Hz Voltage V Frequency Hz Rated load kW Fuse rating A Length of supply lead 78" Supply lead with plug</p> <p>Dryer (EL2) – 2AC 208V 60Hz Voltage V Frequency Hz Rated load kW Fuse rating A Length of supply lead 78" Supply lead with plug</p> <p>Dryer (EL2) – 2AC 220-240V 60Hz Voltage V Frequency Hz Rated load kW Fuse rating A Length of supply lead 78" Supply lead with plug</p>		2 AC 208 / 220-240 60 4 / 4.4 - 5.2 2 x 30 2000 mm NEMA L6-30P 2 AC 208 60 4.84 2 x 30 2000 mm NEMA L6-30P 2 AC 220-240 60 5.7 2 x 30 2000 mm NEMA L6-30P
		<p>Electrical connection must be in full compliance with national regulations and guidelines and with relevant local codes. Similarly, relevant regulations issued by power utilities, occupational safety authorities and insurance companies as well as good installation practices should be observed throughout.</p> <p>Connection to the electrical supply should only be performed by qualified and properly trained persons.</p> <p>Connection using a multi-pole wall lockable socket(s) in compliance with IEC/EN 60309 and IEC/EN 60947 is recommended in order to simplify electrical tests. If machines are hard-wired, a multi-pole main switch must be provided on site. Switches with a contact gap of more than 3 mm can be used. These include switches, fuses and contactors (IEC/EN 60947). A wall socket or electrical isolator must be easily accessible after installation.</p> <p>Reinstallation of the supply point, changes to the equipment or checks on the protective conductor, including determination of correct fuse rating, should only be performed by a properly trained electrician.</p> <p>If necessary, equipotential bonding must be provided in accordance with all appropriate national and local regulations.</p>		

NT

Electrical isolator

Both washer-dryer stack connections must be disengaged by a common electrical disconnect device that switches off all poles in accordance with IEC 60947-1 [Q1].

The electrical isolator [Q1] and plug connections [EL1, EL2] must be located in the immediate vicinity of the machine. Both must be visible, accessible and within easy reach.

If the electrical isolator [Q1] is not in full view of a person performing maintenance work on the machine at all times, the electrical isolator must be fitted with a lock.



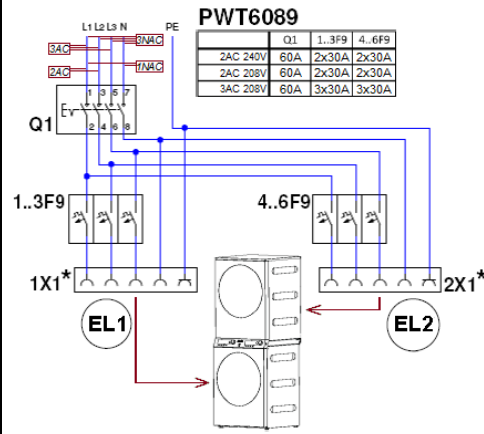

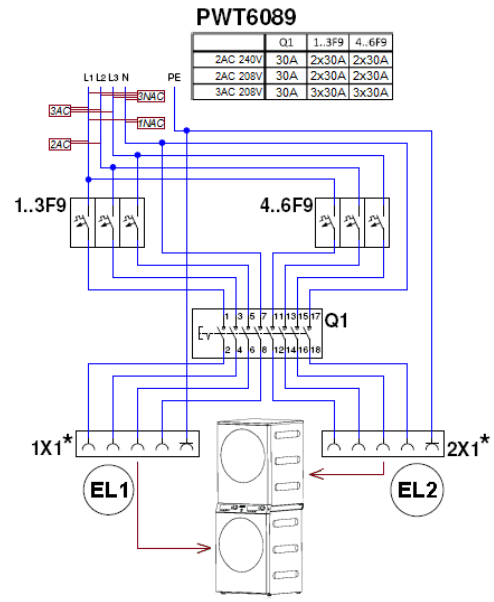

Installation proposals:



-Electrical isolator before fusing-



-Electrical isolator behind fusing-

	Cold water (Soft water)	Min. flow pressure Max. pressure Max. throughput On-site connection thread Length of connection hose (supplied: 1 connection hose) Hourly water demand (average for 60°C program) for standard connection (with hot and cold water) If hot water supply is not available add hot water demand to cold water demand.	14.5 psi 145 psi 2.9 gal/min ¾" external thread 61" approx. 18.5 gal/h	100 kPa 1000 kPa 11 l/min ¾" external thread 1550 mm approx. 70 l/h
	Warm water (Soft water)	Max. temperature Min. flow pressure Max. pressure Max. throughput On-site connection thread Length of connection hose (supplied: 1 connection hose) Hourly water demand (average for 140°F / 60°C program) Machine can be connected to a hot water supply line with a temperature of 158°F (70°C) to max.185°F (85°C). This requires a separate inlet hose. This additional inlet hose is available from Miele. The machine must also be reprogrammed by Miele Service. If hot water is not available, connect hot water hose to cold water valve!	158°F 14.5 psi 145 psi 2.9 gal/min ¾" external thread 61" approx. 18.5 gal/hr	70°C 100 kPa 1000 kPa 11 l/min ¾" external thread 1550 mm approx. 70 l/h
	Drain pump	Max. temperature Drain hose(int. diameter) On-site hose connector for drain hose (int. diameter x length) Max. transient throughput Drain pump head height (from floor level) Vented drainage required. If ventilation is insufficient, Miele installation kit, Mat. no. 05238090. Drain manifolds serving several machines must be of sufficient cross-section.	158°F 7/8" 7/8" x 1 3/16" 6.9 l/min 39 3/8"	70°C 22 [DN 22] mm 22 x 30 mm 26 l/min 1000 mm
	Vented	Nominal air throughput in vented mode Max. permissible pressure loss Waste air/gas temperature, max. Connector on machine (int. diameter) Connection pipe provided on site (ext. diameter) Miele adapter, Mat. no. 6595070 (int. diameter 100 mm) for flexible aluminum ducting and adapter, Mat. no. 915051, (ext. diameter 110 mm) for connection to standard heat- resistant plastic pipes supplied. As relative humidity inside the vent ducting can be as high as 100%, suitable measures must be taken to prevent a backflow of condensate into the machine.	188 cfm 0.06 psi 176°F 4" 4"	320 m³/h 420 Pa 80°C 100 mm 100 mm
	Air intake	Standard connection: => Air intake from installation site Min. air intake cross-section (to prevent draughts in room) A sufficient supply of fresh air should be ensured to replace the air extracted.	37 in²	237 cm²
	Fittings (supplied)	4 x clamps 4 x screws DIN 571 (Ø x length) 4 x rawl plugs (Ø x length) Machine must be bolted to the floor! Fixing materials for a floating screed floor are to be provided on site.	1/4" x 2" 5/16" x 1 9/16"	6 x 50 mm 8 x 40 mm

	Machine data	Unit width Unit depth Unit height Casing width Casing depth Minimum width of delivery access to installation site Recommended rear wall gap Minimum rear wall gap Recommended rear wall gap ensures sufficient space for maintenance and servicing Net weight Dynamic floor load, max. Static floor load, max. Dynamic load, max. Drum frequency, max. Average heat dissipation (dependent on ambient room temperature and program selected) Sound pressure (re 20 mPA), workplace-related (at distance of 3' 3" / 1 m and height of 5'3" / 1.6 m)	27 1/2" 30" 76" 27 1/4" 27 1/4" 28 3/8" 43 5/16" 35 7/16" 463 lbs 3600 N 2850 N 750 N 22 Hz 2830 BTU/hr <70dB(A)	700 mm 752 mm 1930 mm 692 mm 690 mm 720 mm 1100 mm 900 mm 210 kg 3600 N 2850 N 750 N 22 Hz 0.83 kWh <70dB(A)
Installation should only be carried out by authorized installers in accordance with valid regulations! Observe installation instructions when installing machine! All rights reserved!				